



# Abstrakt



**WELSPUN**<sup>®</sup>  
FLOORING

Since its inception in 1985, the Welspun Group has been committed to making India proud globally through its superior quality and innovative products and services. Its brilliant addition, Welspun Flooring, now has a modern manufacturing facility spread over an impressive 300 acres with an investment of more than ₹1150 cr.

A breakthrough in engineering and design, Welspun Flooring brings you a unique meeting of form and function in each collection. This distinctive quality appeals to Architects, Designers, Retailers and Consumers, offering them holistic flooring solutions that spur creative thinking and an elevated sense of design.

## Abstrakt

Abstrakt collection uses visual language of shape, form, colour and line to create a composition which may exist with a degree of independence from visual references in the world. It indicates departure from reality and uses our imagination as its canvas. Using subtle mix of colours to create distinctive visual effects, It is characterized by overlay and versatile coloration.

Abstrakt uses elevated loop technique to create a surface full of texture and depth, which has been designed to suit wide range of ambiances.

  
**WELSPUN®**  
FLOORING



LAVA | CT001656

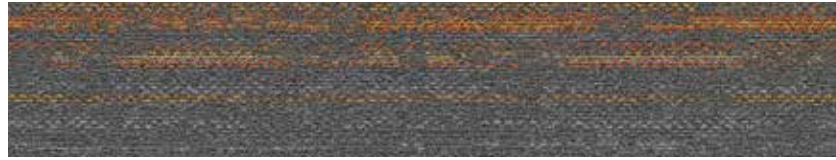

MID-LAVA | CT001667



MIDNIGHT | CT001680



MID-MOSS | CT001668



MOSS | CT001657

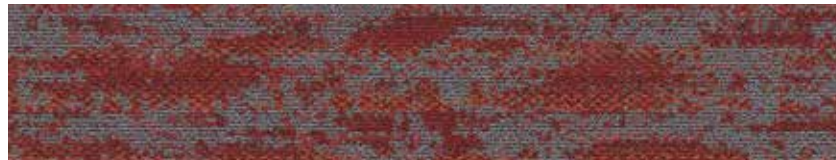

SCARLET | CT001658

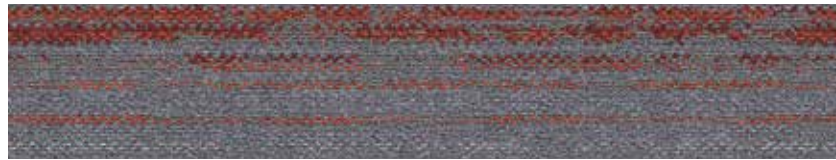

SMOKE-SCARLET | CT001669



SMOKE | CT001679

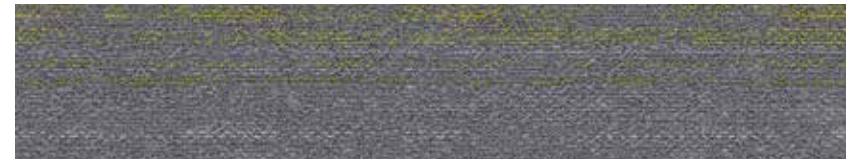

SMOKE-FOREST | CT001670

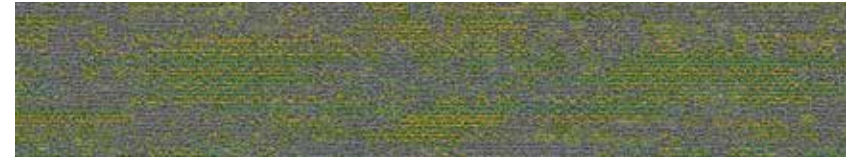

FOREST | CT001659



TEAL | CT001660

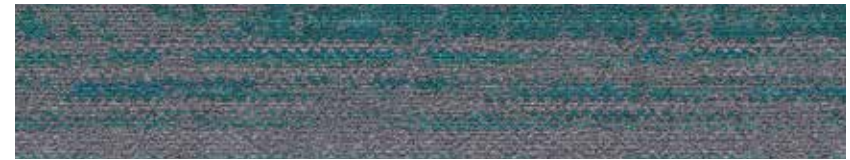

SMOKE-TEAL | CT001671



SMOKE-NAVY | CT001672



NAVY | CT001661

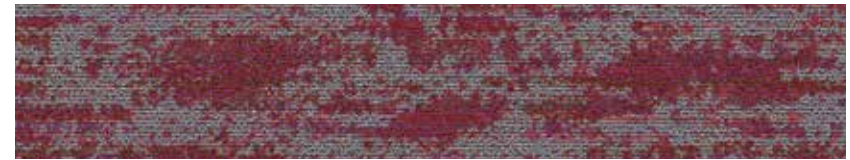

MAUVE | CT001664



FOG MAUVE | CT001675



**FOG** | CT001678



**FOG LIME** | CT001674



**LIME** | CT001663



**FOG PRUSSIAN** | CT001673



**PRUSSIAN** | CT001662



**BRASS** | CT001666

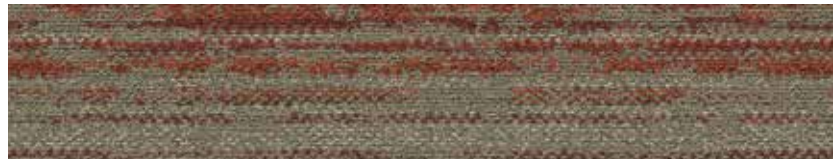

**DUST BRASS** | CT001677



**DUST** | CT001682



**DUST AMBAR** | CT001676



**AMBAR** | CT001665



**UMBRA** | CT001681

# CLICK & LOCK<sup>®</sup>

## TILES



**SILVER STRIPED OAK** | HF001139



**NAPOLI** | HF001329





BRASS | CT001666

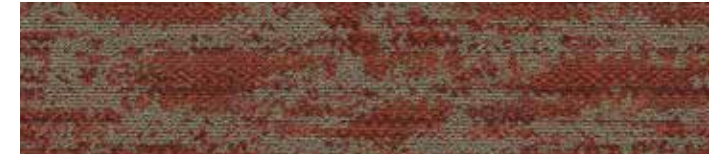

DUST-BRASS | CT001677

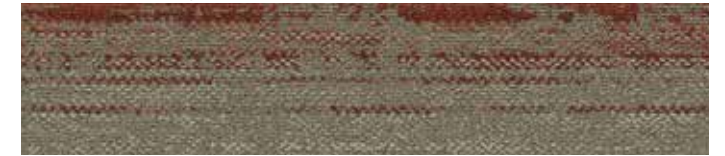

DUST | CT001682

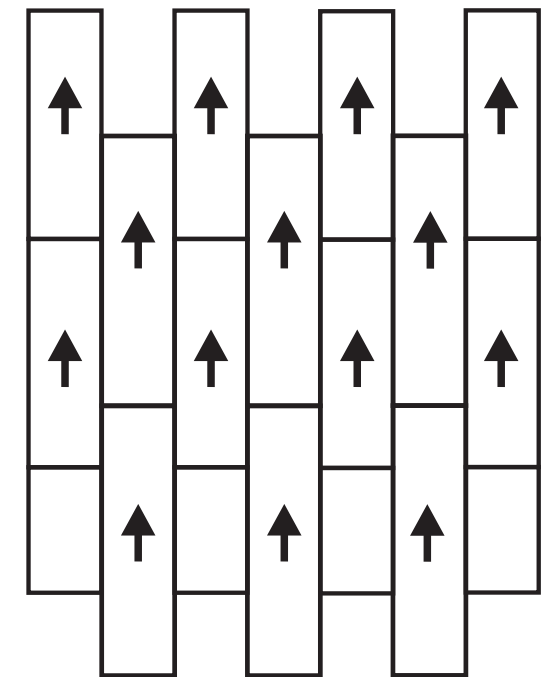



BRASS | CT001666

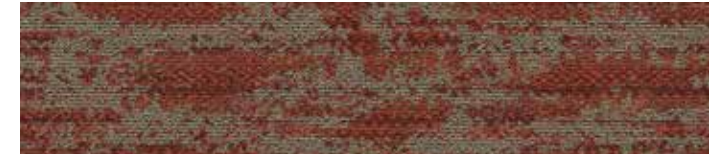

DUST-BRASS | CT001677

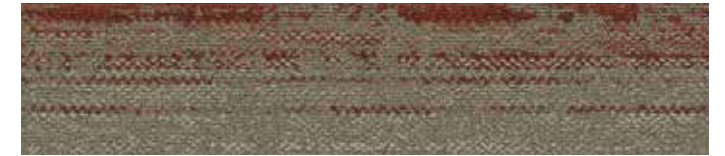

DUST | CT001682

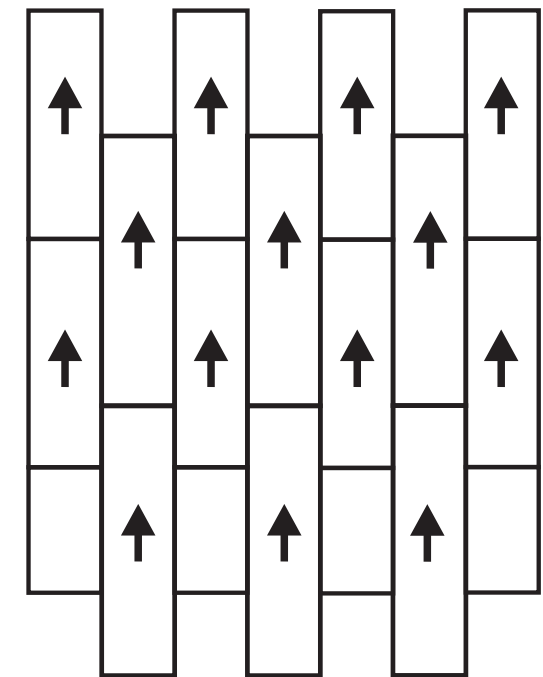



AMBAR | CT001665

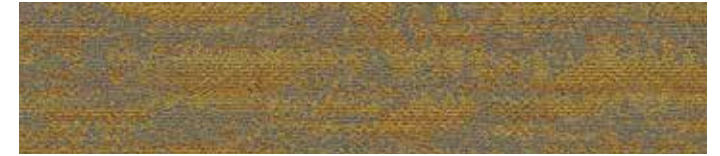

DUST-AMBAR | CT001676

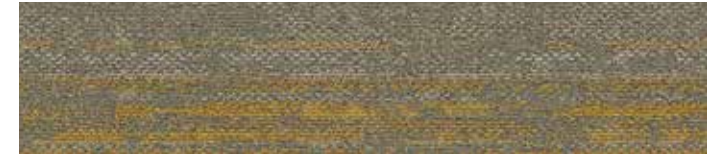

DUST | CT001682

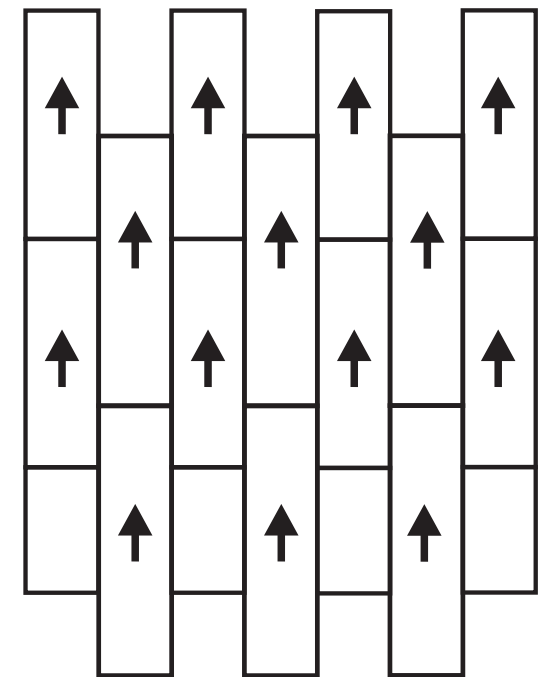





LAVA | CT001656

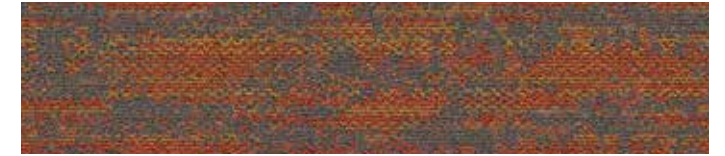

MID-LAVA | CT001667

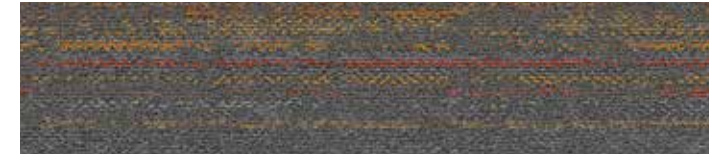

MIDNIGHT | CT001680

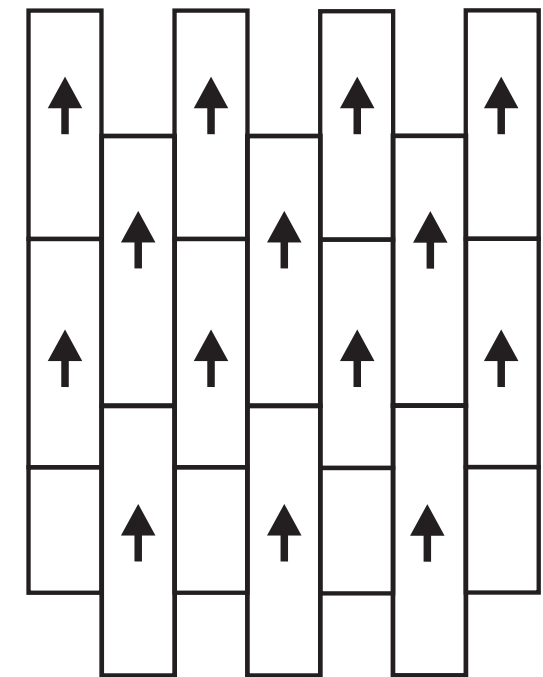
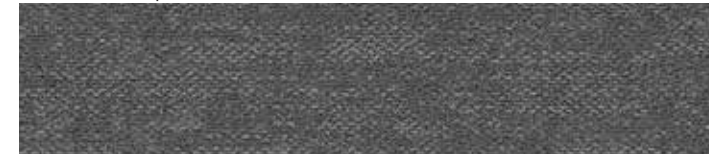



LIME | CT001663



FOG LIME | CT001674



FOG | CT001678

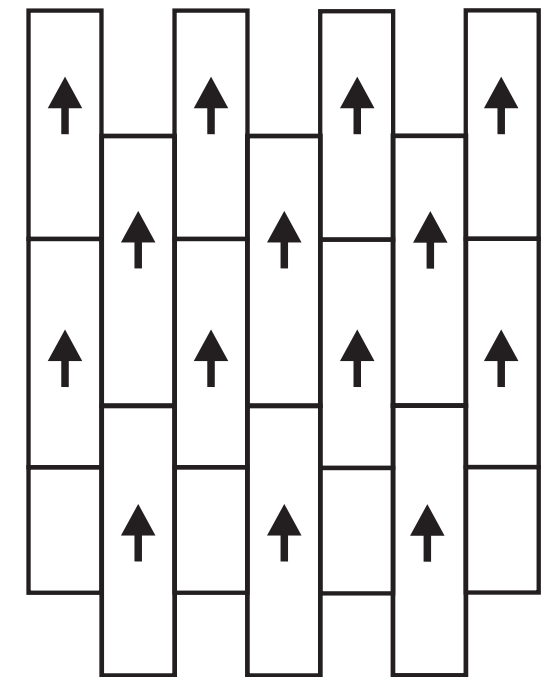

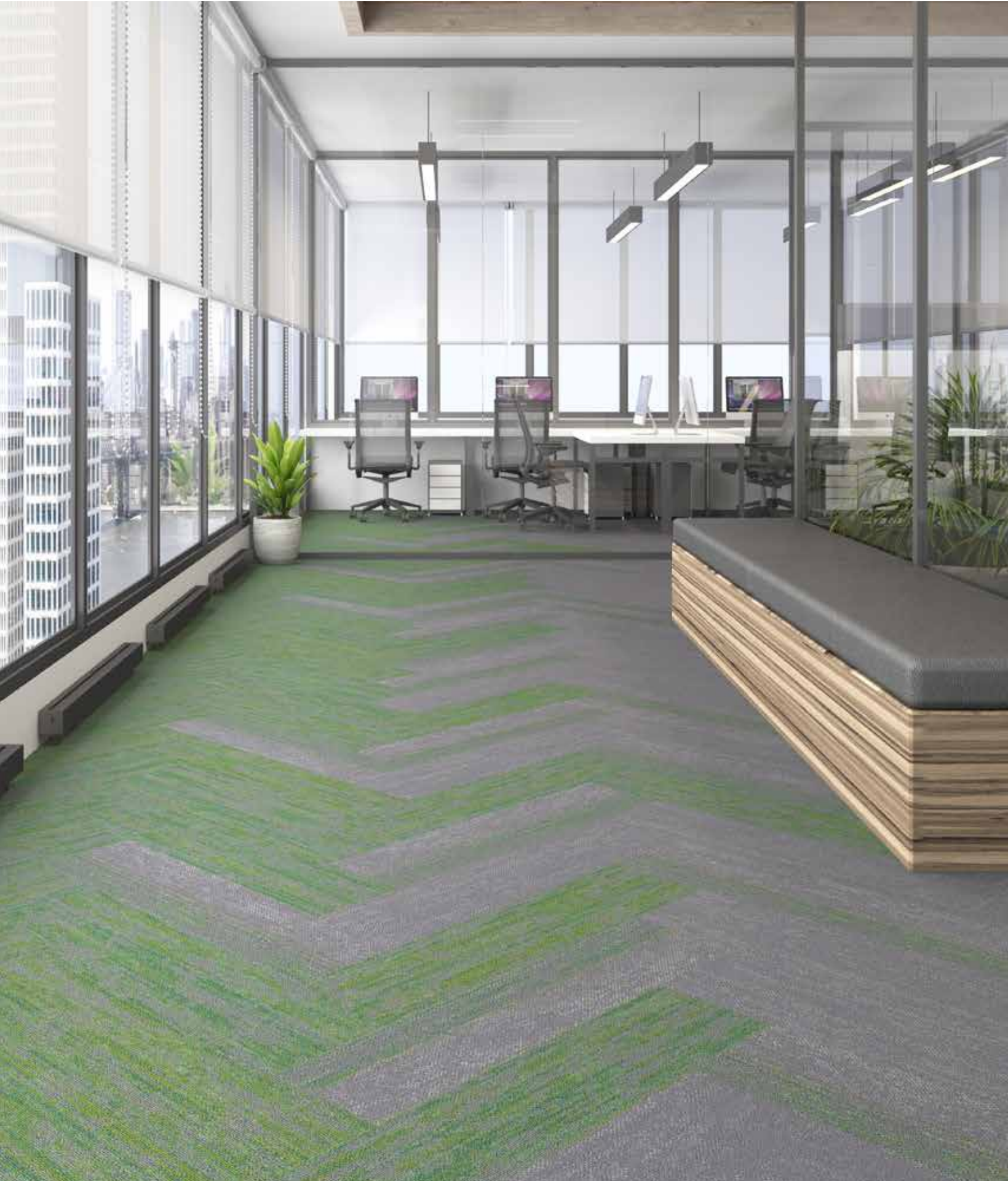

LIME | CT001663



FOG LIME | CT001674



FOG | CT001678

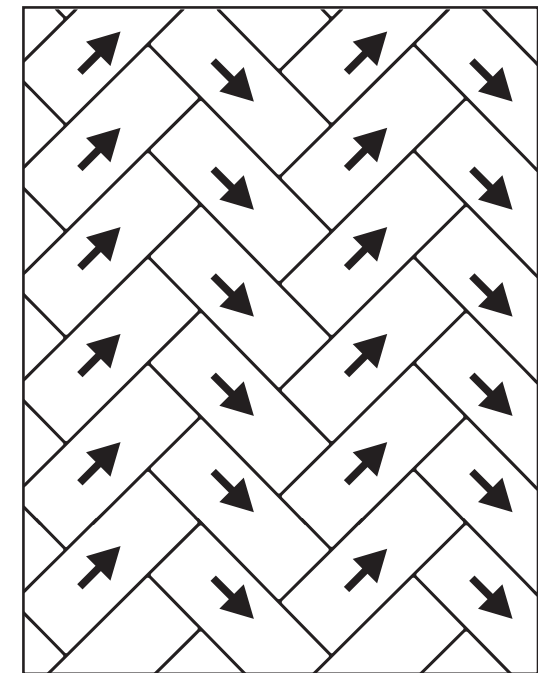
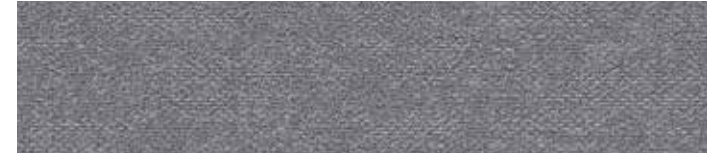



LIME | CT001663

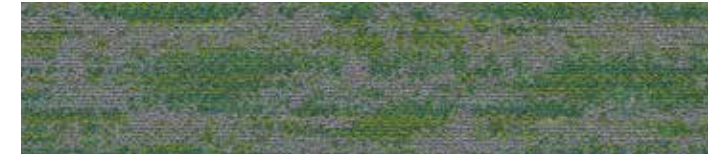

FOG LIME | CT001674



TEAL | CT001660

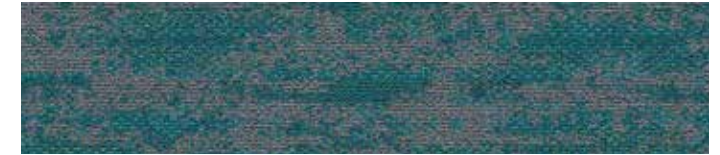

SMOKE-TEAL | CT001671



FOG | CT001678

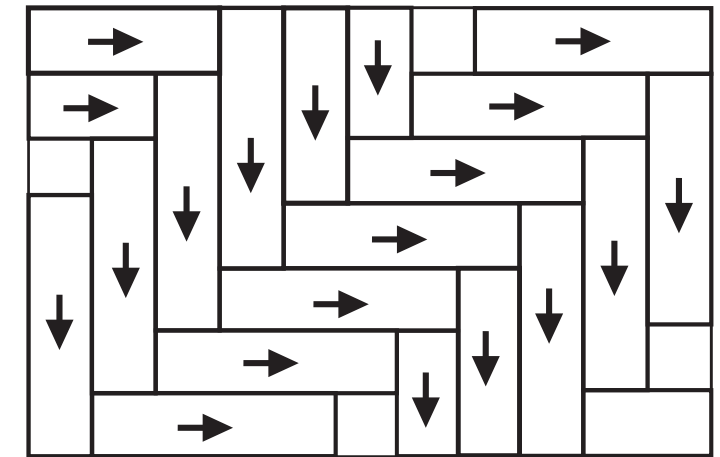



FOREST | CT001659

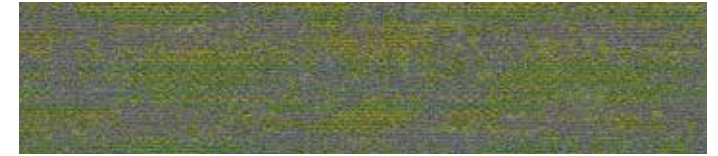

SMOKE-FOREST | CT001670

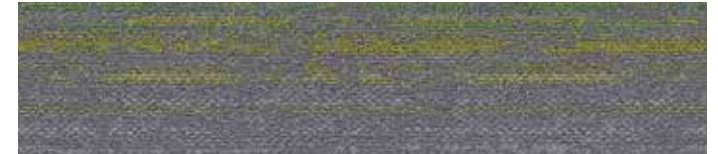

SMOKE | CT001679

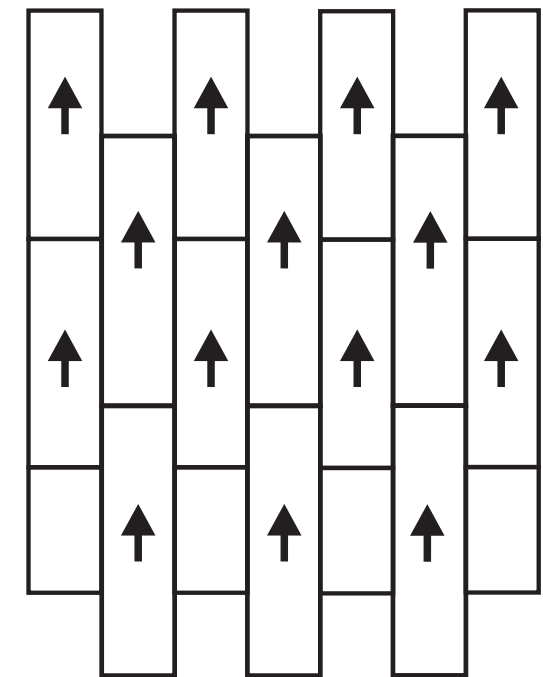
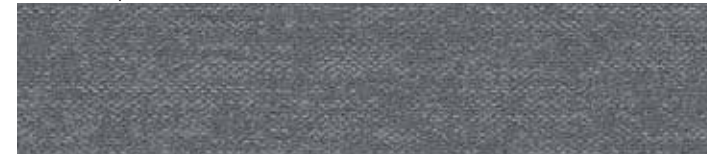



MOSS | CT001657

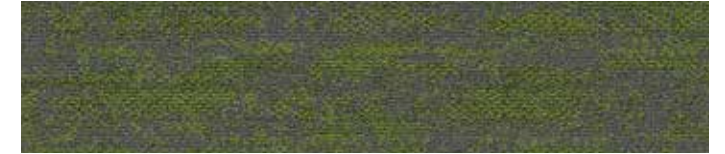

MID-MOSS | CT001668



LAVA | CT001656



MID-LAVA | CT001667



MIDNIGHT | CT001680

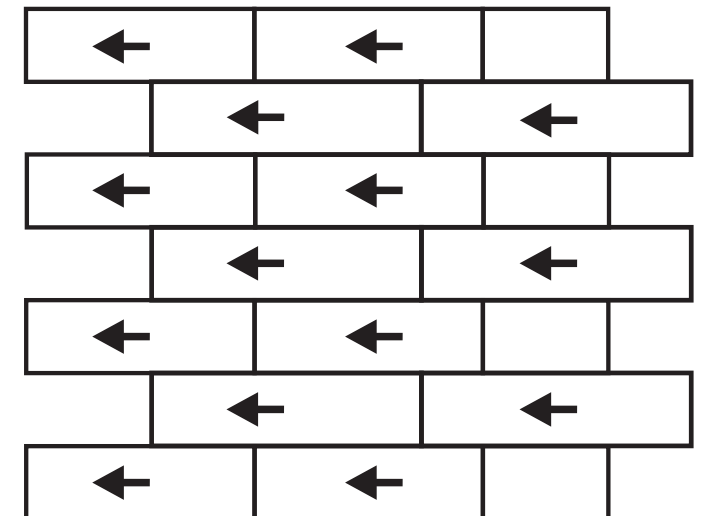
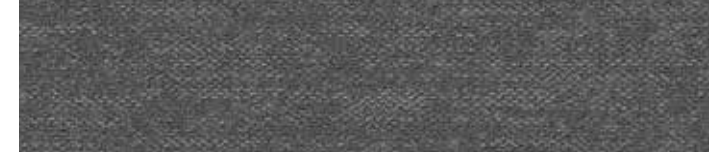



FOG LIME | CT001674



FOG | CT001678

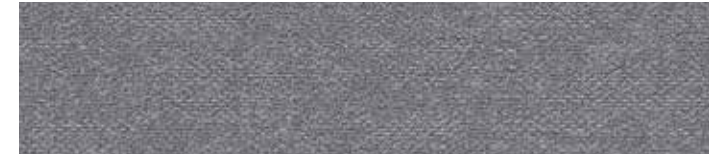

SMOKE | CT001679

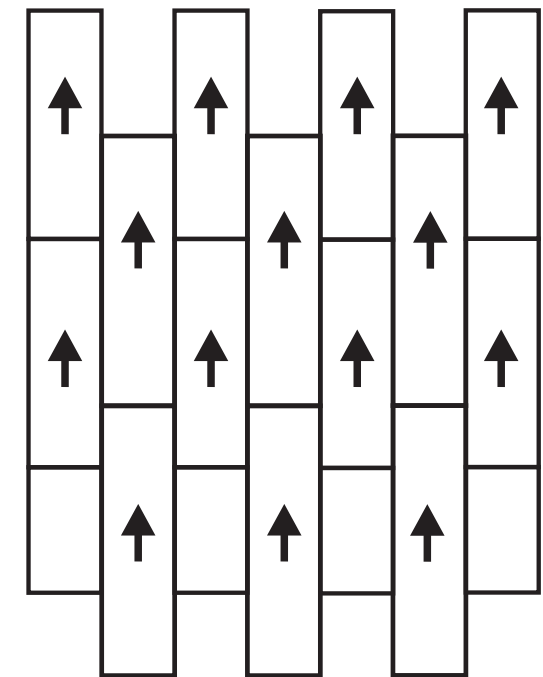
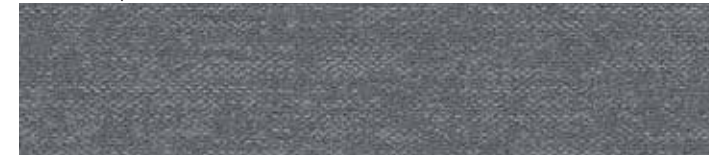



MAUVE | CT001664



FOG MAUVE | CT001675

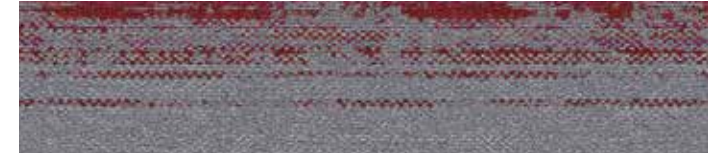

FOG | CT001678

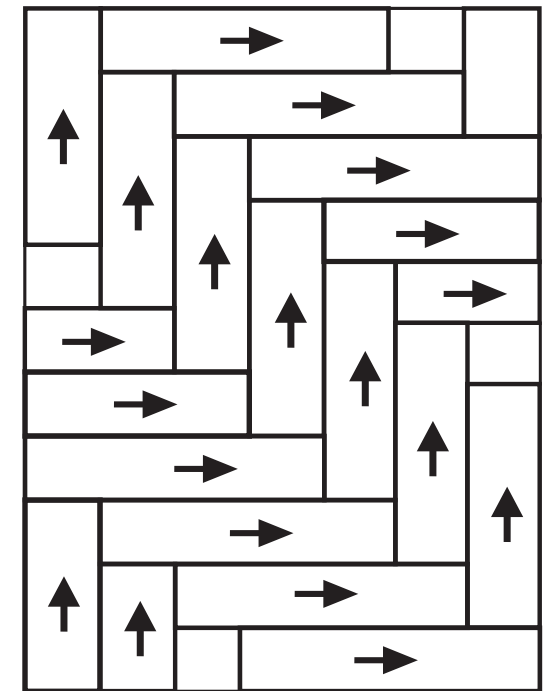





UMBRA | CT001681

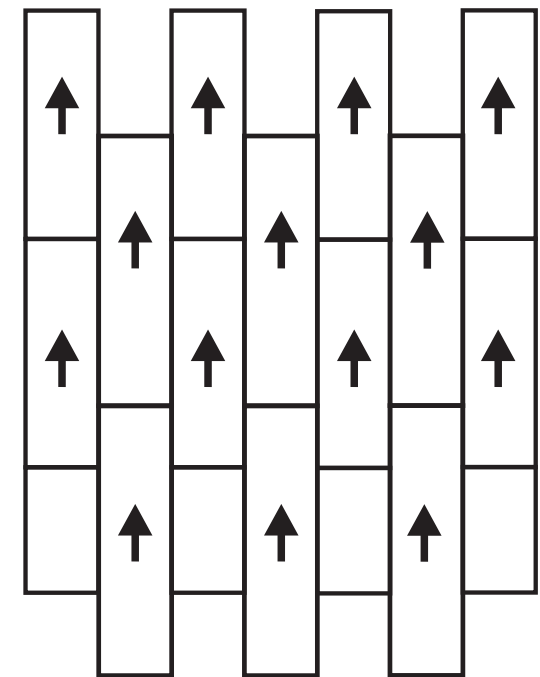

The images used are for illustration purpose only. The actual product appearance may vary.



LAVA | CT001656

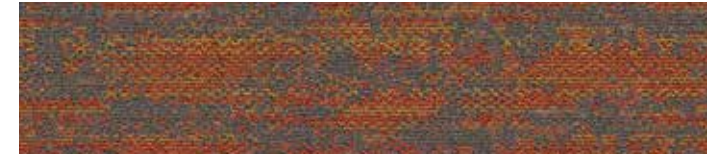

MID-LAVA | CT001667

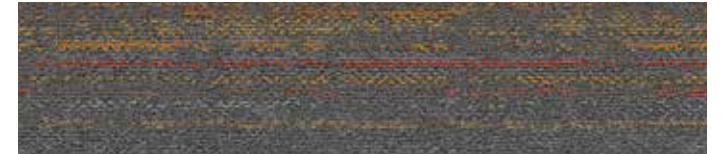

MIDNIGHT | CT001680

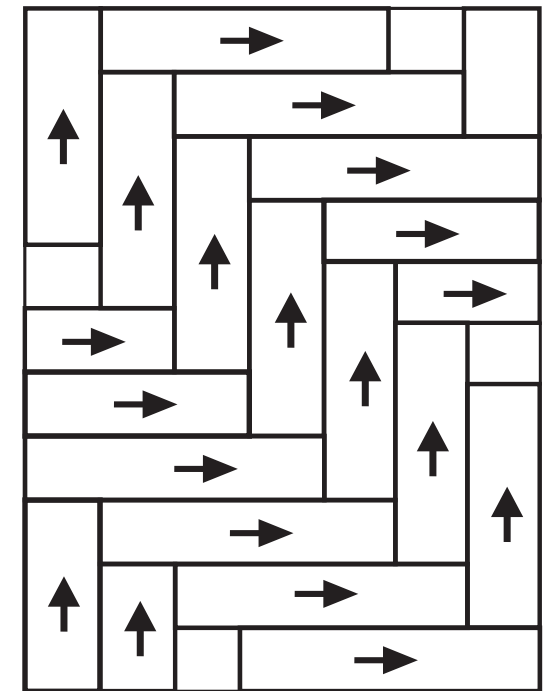
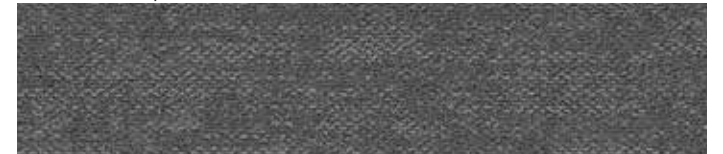

# FUSION FLOORING

CLICK-N-LOCK® + CARPET TILES



TEAL | CT001660



SMOKE-TEAL | CT001671



SMOKE | CT001679



NAPOLI | HF001329



The images used are for illustration purpose only. The actual product appearance may vary.



PRUSSIAN | CT001662



FOG PRUSSIAN | CT001673



FOG | CT001678



SILVER STRIPED OAK | HF001139



## PRODUCT SPECIFICATION

Collection/Design	Abstrakt
Machine/Gauge	1/10 Loop Infinity
Yarn	Nylon 6
Size (CM)	25x100
Pile Height (mm)	3.5-4.0
Total Thickness (mm)	5.5-6.0
Density	5200-5500
SPI	11
Tufting Weight (Oz)	18
Backing System	Welspun Ecolite or Comfortile
Indicates	+/-5%

## TEST REPORT SUMMARY

Test Name	Method	Test Name	Method
Anti Microbial Treatment	AATCC 174 (Part II & III)	Colour fastness to bleach	AATCC 6
Delamination	ASTM D 3936	Static Electricity	AATCC 134-1996
Tuft Bind	ASTM 1335-67	Anti Static	ANSI/ESD S 7.1
Dimensional stability	ASTM D 7570	Castor Chair	DIN 54324
Pile weight	ASTM D 5848-07	Hexapod	ASTM D 5252-15
Pile density	ASTM D 5848-07	Static Coefficient	ASTM C 1028
Total thickness	ASTM D 6988-08	Dimensional stability (Aachen test)	DIN-STD-54318/ITTS-004
Pile height	ASTM D 5823-05a	Anti Soil	ASTM D 6540-05
Gauge	ASTM D 5793-13	Shampoo Fastness	AATCC 138
Tuft density	ASTM D 5848	Water Fastness	AATCC 107
Flammability (Pill Test)	ASTM D 2859	Velcro-Loops	ITTS 112
Flammability (Radiant Panel)	ASTM E 648-06	Heavy Traffic test (Walk test)	ASTM 6119-03
NBS Smoke Density (Flaming)	ASTM E 662-06	Sound transmission	ASTM C 423-17
Lightfastness	AATCC 16 E	Sound Absorption	ASTM C 423-17
Colour fastness to Ozone	AATCC 129	Static Loading	ISO 015/3415
Colour fastness to NO <sub>2</sub>	AATCC 164-2008	Green Carpet (VOC)	ASTM D 5116
Crocking Dry and Wet	AATCC 165-2008	Acoustic	BS EN ISO 354
Stain fastness	AATCC 175-2008/ITTS 002	Thermal Resistance	ASTM C 518

## CARPET TILES ADVANTAGES

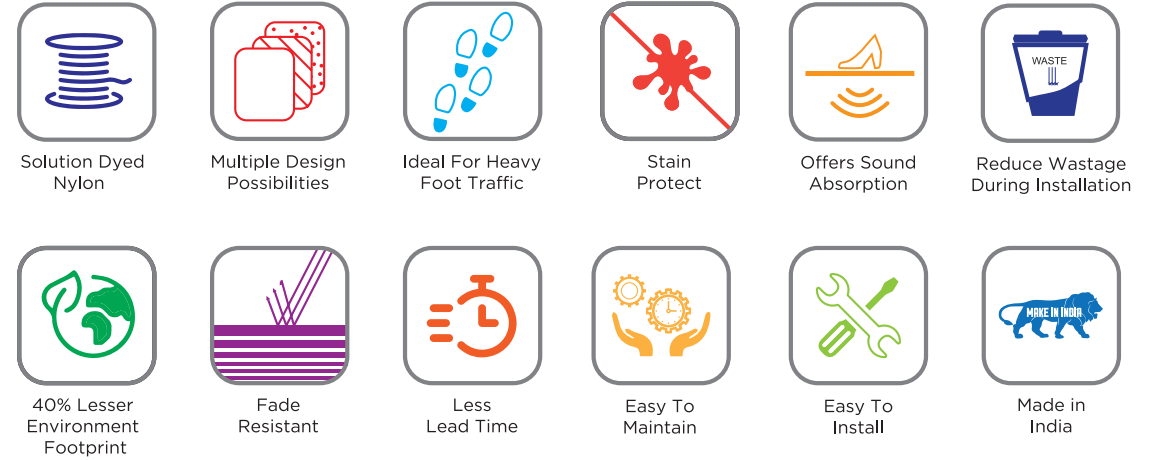

## CERTIFICATION





WELSPUN GLOBAL BRAND LTD,  
SURVEY NO. 190, CHANDANVELLY, NEAR HYTHABAD,  
SHABAD MANDAL, RANGA REDDY (DIST),  
TELANGANA 501 503  
INDIA

Contact us:  
1800 - 120 - 1161  
India: [contact\\_flooring@welspun.com](mailto:contact_flooring@welspun.com)  
Global: [global\\_saleswfl@welspun.com](mailto:global_saleswfl@welspun.com)

[www.welspunflooring.com](http://www.welspunflooring.com)



Scan the QR code to explore  
Abstrakt collection



